

Fred V. Fowler Company, Inc.

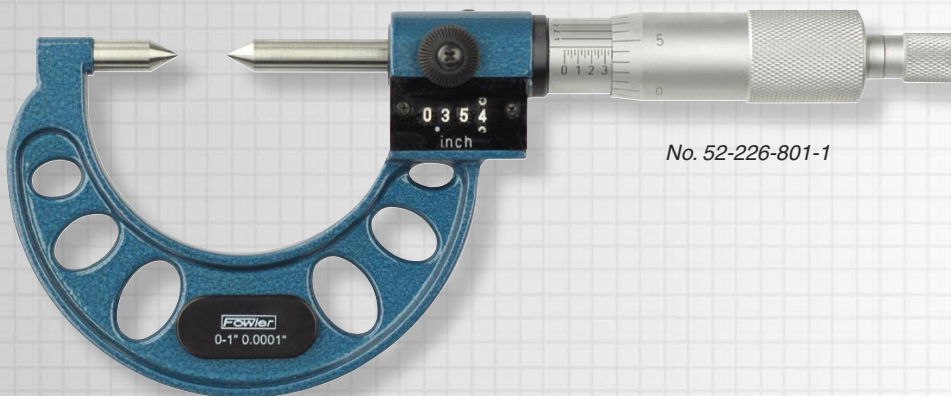

Digit Counter Point Micrometer



No. 52-226-801-1

Use Fowler Digital Point Micrometers for quick and accurate comparisons of thread accuracy in screw cutting operations, for taking measurements of small flutes or recesses, grooved trolley wires and for measuring small grooves, keyways and other hard to reach dimensions.

Anvil and spindle ends are conical and have a radius curvature of .012" at the extremity. Easy to read numbers on the digital counter assure you of accurate, error free readings.

Special Features:

- Hammertone blue baked enamel frame.
- Anvil and spindle are hardened and precision ground with microlap finish on ends.
- Microfine graduations (.0001"/.001mm) on satin chrome finish for easy reading.
- Spindle thread hardened, ground & lapped.
- Quick, easy zero adjustment on sleeve.
- The radius of the measuring points is approximately .012"
- All models feature a ratchet stop thimble for exact and repetitive readings.
- Positive lever locking clamp.
- Accuracy: .00016".
- Includes wrench and fitted case.

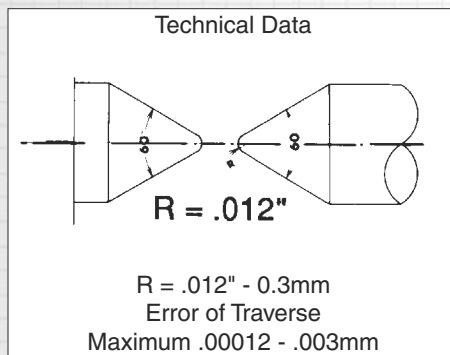

Order No.	Range	Graduation	Point°	Point Length
Inch Series:				
52-226-801-1	0—1"	.0001"	60°	.21"
52-226-802	1—2"	.0001"	60°	.21"