

Fred V. Fowler Company, Inc.



Setting Master Holders

For Cylinder Bore Gages & Universal Bore Gages

Internal & External Measurement

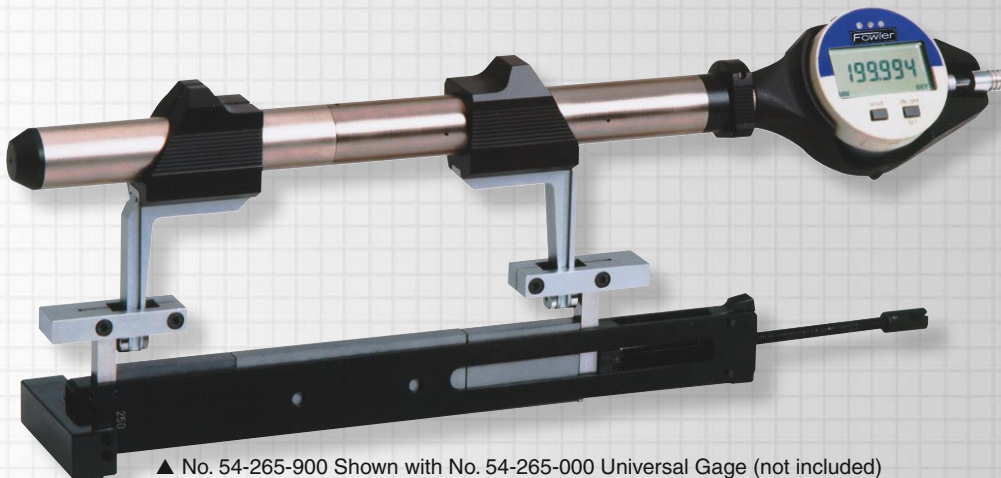

▲ No. 54-265-900 Shown with No. 54-265-000 Universal Gage (not included)

LOW-COST METHODS FOR SETTING ADJUSTABLE GAGES!

Special Features:

No. 54-265-900 and 902:

- Specially adapted gage block holder and arms for quick setting of Bowers Universal Gages
- Use with standard Rectangular Gage Blocks

No. 54-549-900 and 902:

- Specially adapted Gage Block Holder and arms for quick setting of most brands of Cylindrical Bore Gages
- Use with standard rectangular Gage Blocks
- Requires at least one pair of Setting Blocks



▲ No. 54-549-900 Shown with No. 54-549-906 and Digital Cylinder Bore Gage (not included).

Order No.	Description
<i>for Universal Gage</i>	
54-265-900	0—9" Setting Master Holder Kit
54-265-902	0—15" Setting Master Holder Kit
<i>for Cylindrical Bore Gages</i>	
54-549-900	1/2—6" Setting Master Holder
54-549-902	1/2—12" Setting Master Holder
54-549-904	1/2—7/8" Pair of Centralizer Setting Blocks
54-549-906	7/8—6" Pair of Centralizer Setting Blocks
54-549-908	6—12" Pair of Centralizer Setting Blocks