



Ultra-Light Mark III Electronic Caliper



Fowler/Sylvac's lightweight heavy-duty electronic digital calipers include sizes up to 60"(1500mm) and resolution of .0005"(.01mm). This has been achieved by designing a well-balanced instrument utilizing state-of-the-art material technology. Functional parts are made of the latest wear-resistant materials. Hollow section aluminum beam reinforced by two stainless steel guides. This system assures perfect guidance and protects the beam against shocks.

Constant measuring pressure control ensures constant measuring force and parallel pressure on jaws. It's important with large calipers, since measuring pressure plays an important part when checking large diameters on bores.

These Calipers offer many advantages over conventional calipers:

Lightness improves measuring results. Measuring pressure control for improved repeatability. All work contact faces are titanium-coated on hardened steel or are solid carbide. Fixed left jaw increases rigidity.

Special Features:

- Internal and external measurements with two presets.
- Min/Max functions.
- Hold feature freezes display for later viewing.
- Incremental floating zero.
- Large, high-contrast LCD display indicates in/mm, hold and zero functions.
- New low drain, high efficiency lithium wafer battery—4500 hrs. of continuous on-time.
- Direct inch/metric conversion.
- **Direct RS232C output** connects tool to any computer or printer without an interface.
- Special application accessories available.
- Includes fitted wooden case.
- Extended measuring range available call the Fowler Technical Dept. for more information.

Specifications:

- External Jaws: Length: 6"(150mm); thickness: .4" (10mm); material: titanium coated stainless steel.
- Internal Pins: Length: .71" (18mm) diameter: .2" (5mm); material = tungsten carbide.
- Measuring Speed: 60"/1.5m per second

Order No.	Range	Accuracy	Repeatability	Weight
54-110-312	0-12"/300mm	.0012"(.03mm)	.0008"(.02mm)±2s	2.4lb(1.1kg)
54-110-324	0-24"/600mm	.0016"(.04mm)	.0008"(.02mm)±2s	2.9lb(1.3kg)
54-110-340	0-40"/1000mm	.0024"(.06mm)	.0008"(.02mm)±2s	3.5lb(1.6kg)
54-110-360	0-60"/1500mm	.006"(.15mm)	.0008"(.02mm)±2s	4.4lb(2kg)
54-110-412	Replacement case for #54-110-312			
54-110-424	Replacement case for #54-110-324			
54-110-440	Replacement case for #54-110-340			
54-110-460	Replacement case for #54-110-360			
54-115-333	Simplex Connection Kit. Includes 80"(2m) connecting cable with 9 pin IBM compatible connector, support disk and instruction book.			
54-100-350	Type CR2032 replacement battery			

Fred V. Fowler Company, Inc.

Ultra-Light Mark III Calipers (continued)

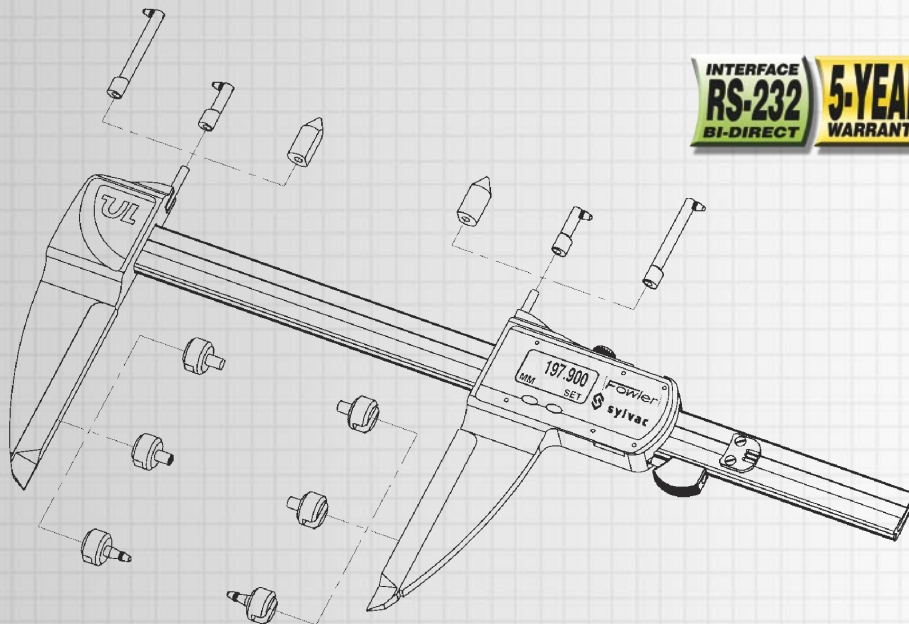
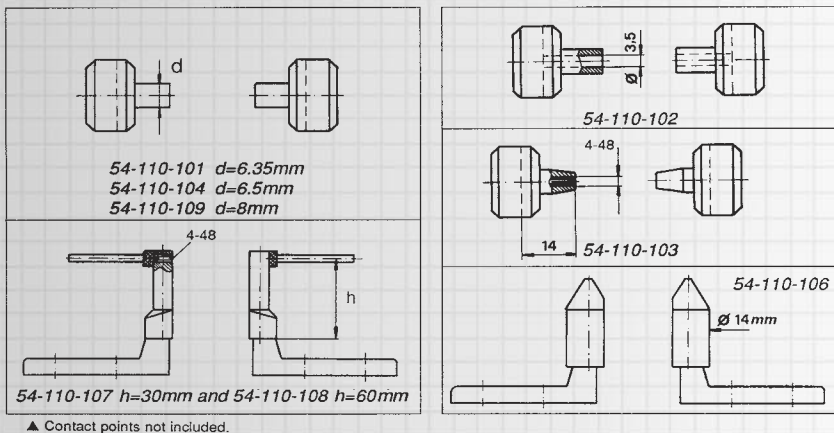

Order No.

Description

54-110-000	Stand for 54-110 series
54-110-101	Thread wire holder, diameter 6.35mm (pair)
54-110-102	Thread insert holder, diameter 3.5mm (pair)
54-110-103	Contact Point holder, 4-48 thread (pair)
54-110-104	Thread wire holder, diameter 6.5mm (pair)
54-110-105	Adjustable stop
54-110-106	Centerline cones 14mm (pair)
54-110-107	Groove attachment, 30mm (pair)
54-110-108	Groove attachment, 60mm (pair)
54-110-109	Thread wire holder, diameter 8mm (pair)
54-110-110	Fine adjustment device